

Gerd Lehmann

FULL DENTURE COURSE

MASTER COURSE

TOOTH SETUP
MODIFIED ACCORDING
TO PROF. GERBER

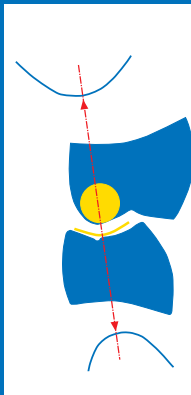

SUPPORTED BY MERZ DENTAL

1. MODEL ANALYSIS	5 - 11
2. SETTING UP THE FRONT TEETH	12 - 13
3. SETTING UP THE POSTERIOR LOWER JAW	14 - 17
4. SETTING UP THE POSTERIOR UPPER JAW	18 - 21
5. SELECTIVE GRINDING IN	22

THE AUTHOR

Gerd Lehmann, master dental technician, worked for many years in renowned Swiss dental laboratories, also in a managerial role as department head.

He took interest at an early stage in the principles of the set-up method according to Prof. Gerber - condylar theory - the logic and philosophy of this method convinced and fascinated him. In various joint advanced training courses he worked together with Prof. A. Gerber as a speaker.



A new professional challenge necessitated his move from Zurich to Munich, where he took over the management of a renowned dental laboratory. Soon he was offered a position at the newly founded Master school of dental technicians in Munich, firstly as an instructor then later in 2012 as its director.

His specializations were in milling, attachment and locking techniques, in implantology and full dentures. Besides numerous activities as a speaker and author, but also as an appointed expert for the Munich Chamber of Trade (HWK), as chairman of the examination boards for the apprentice and master craftsman's diploma, Gerd Lehmann, who is retired, but not tired, is still in international demand as a course leader.

1st edition 01/2015



© Merz Dental GmbH

Reprinting, even in part, only with the consent of Merz Dental GmbH, Eetzweg 20, 24321 Lütjenburg
Printed in Germany

The aim and object of successful full denture restoration is to restore the patient's lost quality of life. The most important demands placed on the full denture include

- restoration of aesthetics
- restoration of masticatory function
- restoration of pronunciation, i.e. articulation
- restoration of an essentially physiological perioral appearance



Prof. Dr. Albert Gerber

Photo G. Lehmann, master dental technician, Munich



DeltaForm® teeth from Merz Dental according to the mortar-pestle principle

Total prosthetics are to this day influenced by **Prof. Albert Gerber's** concepts. He took over the chair at the Department for Prosthetics and Temporomandibular Disorders at the Dental Institute of the University of Zurich from Prof. Alfred Gysi, the doyen of modern prosthetics. Prof. Gerber developed the **so-called Condylar Theory**. Its features: **lingualised, bilateral balanced occlusion**, tooth-to-tooth occlusion and **mortar-pestle posterior teeth** coordinated with this.

1. MODEL ANALYSIS

Purpose of the model analysis

The aim and purpose of a prosthetic restoration is to restore the patient's quality of life after the loss of their teeth. The requirements the patient places on the denture are:

- restoration of aesthetics
- masticatory function
- correct phonetics

In order to be in a position to fulfil these requirements with the fabrication of full dentures, a model analysis is necessary prior to the process of tooth set-up.

Scope of the model analysis

The model analysis provides the dental technician with important information as to where the teeth stood before their loss and where the replacement teeth have to be set up according to prosthetic, functional and static considerations, such that the muscular balance is not disturbed.

The model analysis of the edentulous models consists of:

- model study
- marking of the static lines (straight lines on the middle of the alveolar ridge) in the lower and upper jaws
- determination of the intermaxillary relationship between the jaws
- marking the sagittal contour of the alveolar ridge
- determination of the masticatory centre and the stop line
- evaluation of the model analysis

The model analysis includes assessment of the anatomical shape of the lower and upper jaws and the intermaxillary relationships of the jaws in the transversal and sagittal directions, as well as determining the occlusion concept according to which the tooth set-up is to be carried out, e.g.

- normal bite
- unilateral cross-bite
- bilateral cross-bite
- lingualised, balanced occlusion according to Prof. A. Gerber

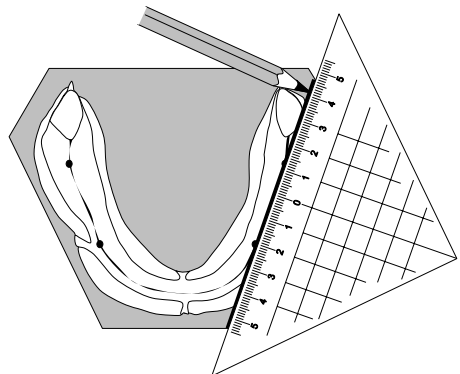

Determination of the alveolar ridge line - static line

In the posterior region of the lower jaw, the contour of the alveolar ridge (mid ridge) is marked with pencil dots in the region of the canine / 1st premolar and in the region of the molars.

In the posterior region of the upper jaw, the contour of the alveolar ridge is also marked with dots in the region of the canines / 1st premolars and in the region of the molars.

The two dots on each side of the alveolar ridge are interconnected to form a straight line, the static line. The line is extended towards the outside on the model base with a vertical line.

The area in which the lines leave the middle of the alveolar ridge is also marked with a vertical line on the model base. This is the critical area for masticatory stability of the canine / 1st premolar region.

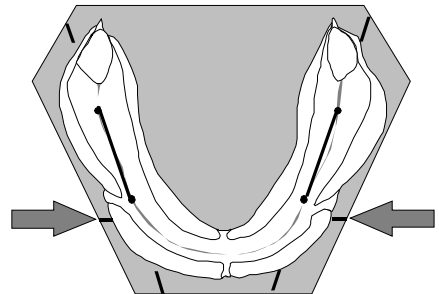
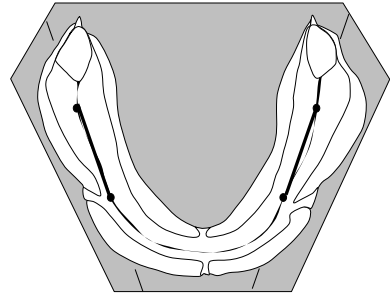
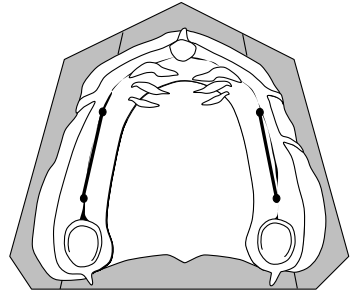

Sagittal alveolar ridge contour

The ridge contour can be transcribed precisely to the side face of the model base using the profile compass.

For marking the sagittal contour of the alveolar ridge in the lower jaw, the pencil tip must be in contact with the model base. The position of the metal loop and the pencil is vertical and must always run at a right angle (90°) to the alveolar ridge profile.

The lowest point of the alveolar ridge profile is taken from the markings to trace the alveolar ridge contour.

Here it is important that during marking, the metal tip of the loop is in contact with the alveolar ridge.

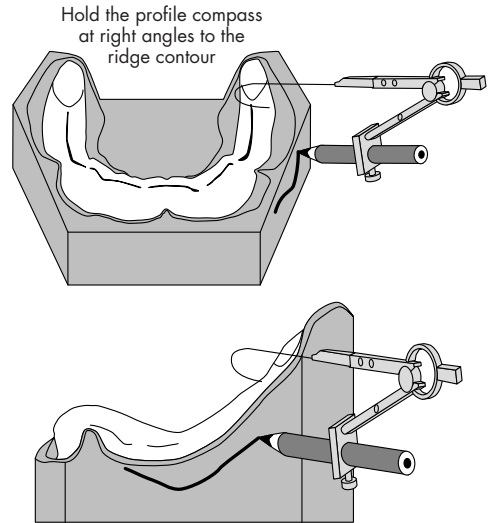

Masticatory centre

The tangent that touches the lowest point of the alveolar ridge is parallel to the occlusion line. The line of this tangent is drawn with the aid of a ruler.

The lowest point of the line of the alveolar ridge is the central area of the masticatory centre.

The middle of the masticatory centre is marked with a blue vertical line. The tolerance range of the masticatory centre is specified as approx. 1 mm both to the mesial and the distal and roughly corresponds to the size of the fossa of the lower 1st molar.

The limits of the tolerance range have to be marked with green vertical lines.

The largest masticatory unit is set up from the masticatory centre, usually it is the 1st molar.

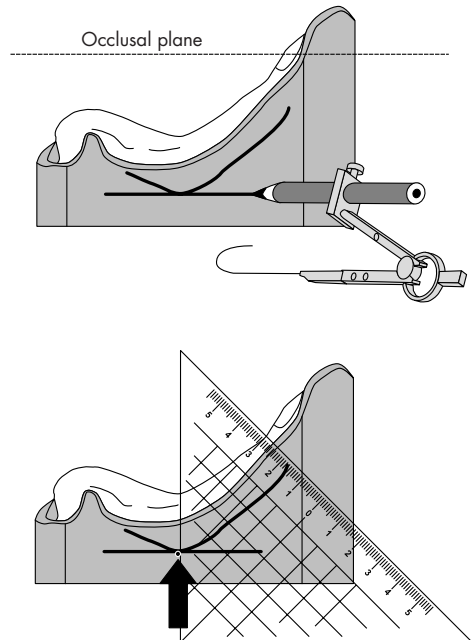

Stop line

A 22.5° angle template is used to determine the intersection point on the model base with the marking of the alveolar ridge contour and the tangent also marked, which, as described, runs parallel to the occlusal plane. The intersection point corresponds to the position of the stop line.

Please note: The set-up ends at the point at which the rising branch of the lower jaw is steeper than the horizontal condylar inclination (HCI). This is important to achieve approximate parallelism between the HCI and the protrusion faces of the posterior teeth. The stop line is the dorsal limit of the posterior set-up.

The lowest point of the masticatory centre corresponds with the marking of the sagittal alveolar ridge contour. Distal of the masticatory centre, the rising branch of the lower jaw rises and forms an inclined plane in this area. The stop line runs in front of the inclined surface, i.e. an inclined plane. The stop line is marked with a red vertical line. It is the dorsal limit of the posterior set-up, which is loaded by antagonists in static and dynamic occlusion.

According to the anatomical conditions, the alveolar ridge rises after the stop line. The denture base in this area is equivalent to an inclined plane. A tooth on this inclined plane causes a tilt with loading in the centric position. The denture slides forwards and lifts up in the diagonal direction. Masticatory stability is lost. According to Prof. Gerber, this phenomenon is termed anterior sliding and should be avoided.

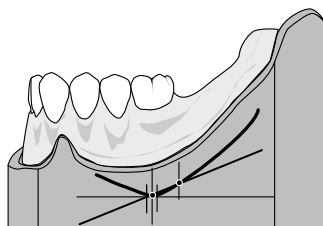
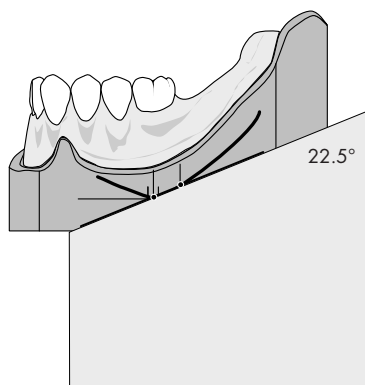
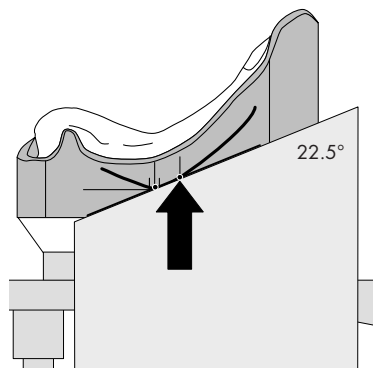

Evaluation of the model analysis

A correct tooth set-up assumes evaluation of the measurements and reference lines from the model analysis of both jaws.

Dorsal position of the alveolar ridge lines (static lines)

After mounting the model in the articulator and determining the static lines (middle of the alveolar ridge) of the lower and upper jaws, the intermaxillary relationship of the jaws to each other can be found by marking the lines on the dorsal side of the model base are marked on each side of the jaw with a vertical line. The relation to the occlusal plane and to the dorsal marking on the upper and lower jaws shows the intermaxillary relationship. This relationship is considered to be in balance if the connecting lines between the alveolar ridge midlines of the upper and lower jaw are at an angle greater than 80° to the occlusal line.

Given a balanced intermaxillary relationship, a normal bite should be set up, whereas given an angle of less than 80° , a unilateral or bilateral cross bite must be set up.

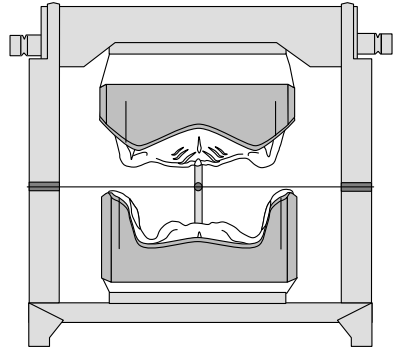

Alveolar ridge relationship

The decision whether the posterior teeth have to be set up with a normal bite, unilateral or bilateral cross bite is determined from the ridge position angle. This goes back to Gysi and the models mounted in the articulator are viewed from dorsal for this purpose and a rubber ring or similar marks the masticatory/occlusal plane. A tooth carrier, protractor or a short ruler is held left and right on the upper and lower ridge middle marking. If the angle with the masticatory/occlusal plane as apparent using the tool is less than 80° , there is cross bite, if the angle is equal to or greater than 80° , the set-up is that of a normal bite.

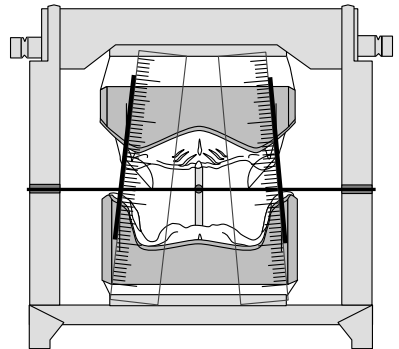

Evaluation of the alveolar ridge profile

The sagittal marking of the alveolar ridge profile of the lower jaw marks the profile of the alveolar ridges in the sagittal direction. It is transcribed to the model base using the profile compass.

The masticatory centre (= lowest point of the alveolar ridge contour) is in front of the red marked stop line, above which the largest masticatory unit is set up. This is usually the lower 1st molar.

Please note: Distal of the stop line, the rising branch of the lower alveolar ridge forms an inclined plane. No tooth may be set up here, which has antagonist contact in static and dynamic occlusion.

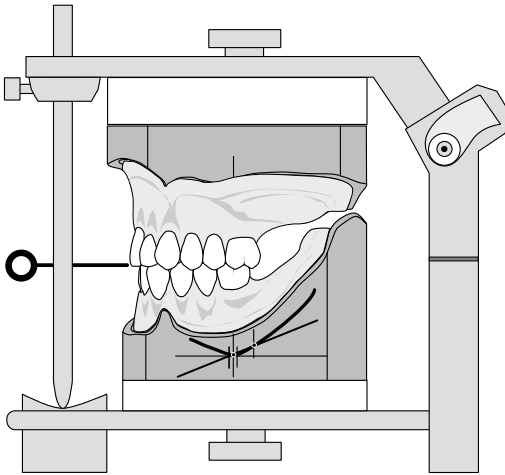

Guidelines for rational tooth set-up according to Prof. Gerber Setting up step-by-step

Front teeth

- Teeth 31 and 41
- Teeth 11 and 21
- Teeth 32 and 42
- Teeth 33 and 43
- Teeth 12 and 22
- Teeth 13 and 23
- The functional space / overjet is checked.
- Procedure on the condylar:
To check the functional space / overjet - loosen the fixing screws on the articulator and move both adjusters to the top position. Then tighten the fixing screws on both sides in this position and simulate dynamic occlusion movements. After checking, loosen the fixing screws and move the adjusters back to the 0 position (dropped) and lock in this position.

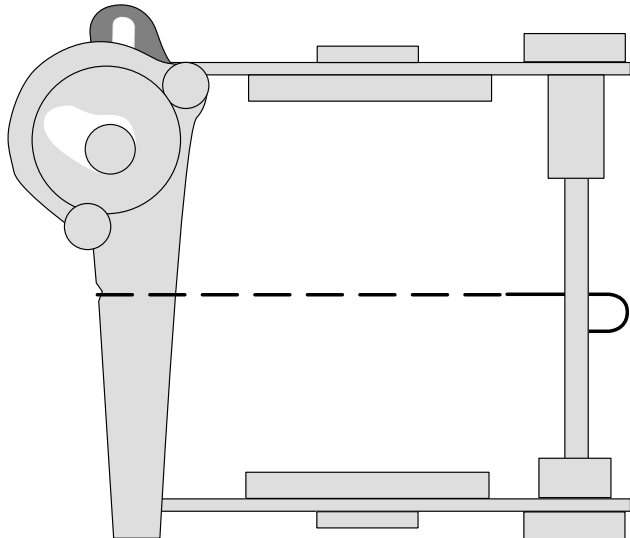

Posterior teeth

- Tooth 34
- Tooth 24
- Tooth 35
- Tooth 36
- Tooth 37, provided the position of the stop line allows this
- Apply wax on the left side of the lower jaw for modelling later on. While the wax hardens, the teeth on the right side are set up.
- Tooth 44
- Tooth 14
- Tooth 45
- Tooth 46
- Tooth 47, provided the position of the stop line allows this.
- Apply wax on the left side of the lower jaw for modelling later on. While the wax hardens, the teeth on the left side of the upper jaw are set up.
- Tooth 25
- Tooth 26
- Tooth 27, provided the position of the stop line allows this.
- Apply wax on the left side of the lower jaw for modelling later on. While the wax hardens, the teeth on the left side of the upper jaw are set up.
- Tooth 15
- Tooth 16
- Tooth 17, provided the position of the stop line allows this.
- Apply wax on the right side of the upper jaw for modelling later on and during this time start with modelling in the lower jaw according to muscle gripping, physiological criteria and then give the denture body its functional shape.
- Modelling the upper wax set-up.
- Checking the centric contacts with red occlusion foil.

2. SETTING UP THE FRONT TEETH

Lower front teeth

The incisal edges of the four incisors and the tips of the canines lie on the height of the occlusal plane, the rubber band, that represents the occlusal plane in the articulator. The axial position of the lower front teeth is variable and a harmonious overall appearance is strived for.

The lower 1st incisors viewed labially stand perpendicular to the occlusal plane, approximately their incisal edges are inclined slightly labially.

The lower 2nd incisors viewed labially stand slightly inclined distally in relation to the occlusal plane. Viewed approximately, they stand almost perpendicular to the occlusal plane.

The lower canines stand inclined distally when viewed labially. Viewed approximately, the tooth neck is inclined further labial than the incisal edge.

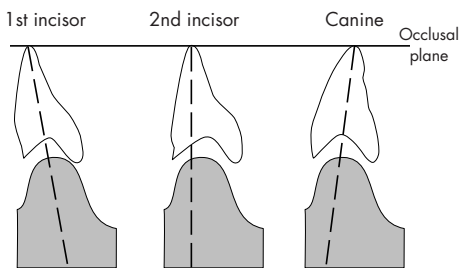
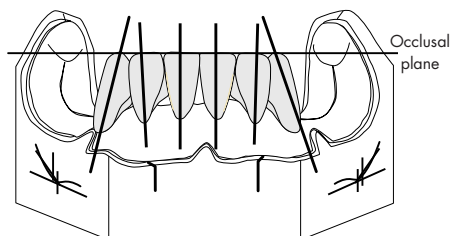

The functional space, the overjet

In natural dentition, the functional space, the so-called overjet, between the front teeth of the upper and lower jaws does not exist.

However, in the case of removable dental prosthetics, especially full dentures, a functional space, the overjet is required.

In the full denture there is a functional space - the overjet - necessary between the lower front teeth and the upper anterior teeth, according to the overbite of the anterior teeth. Prof. A. Gysi formulated the "overbite = overjet" rule here, which means that for an overbite of 2 mm the overjet is also 2 mm.

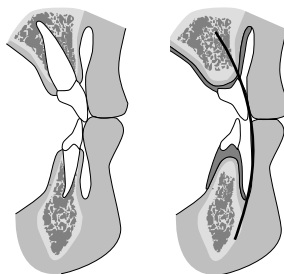

Upper front teeth

Teeth 11 and 21

- According to the midline marking and position of the lower front teeth
- 1.5 - 2 mm overbite and corresponding identical underbite as overjet
- In the 180° angle (semicircle), the incisal edges of the 1st incisors point to the middle of the mucolabial fold
- Axial tilt in the labial view is almost perpendicular to the occlusal plane

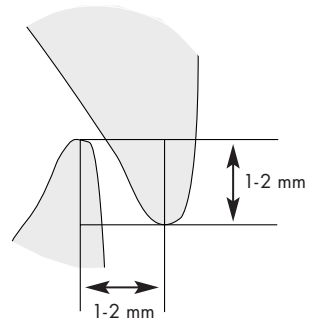

Teeth 12 and 22

- Overbite and underbite approx. 0.5 - 1.5 mm, i.e. less than the two 1st incisors
- Strive for a harmonious front teeth arch
- Axial tilt in approximal view approx. 10° (distal inclination)



Teeth 13 and 23

- Orientation according to the canine line markings, such that the canine tips lie on this line
- Canine tips usually stand on the same height as the incisal edges of the two upper 1st incisors
- Overbite as with the two upper 1st incisors
- Overjet harmonious with the two upper 1st and 2nd incisors
- No canine guidance, balanced occlusion is strived for here
- Viewed from approximal, the tooth neck can be inclined slightly more labially than the canine tip

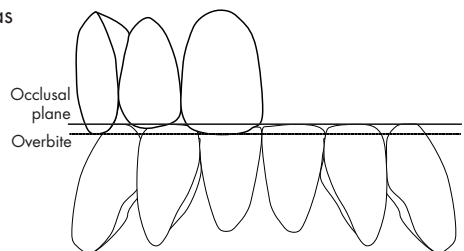

3. SETTING UP THE POSTERIOR LOWER JAW

In the case of the premolars, the tooth axes are inclined distally, a height difference arises between the distal marginal ridges of the 1st premolars, the mesial marginal ridges of the 2nd premolars and to the molars. The height differences have to be identifiable as small steps.

When selectively grinding in the tooth-guided movements, grinding takes place around these steps, such that there is support at every posterior tooth during protrusion.

First lower premolars (teeth 34, 44)

Buccal view

The 1st premolar has mesial contact to the canine, no gaps if possible. The tooth axis is slightly inclined distally (approx. 10°). Buccal cusp tip approx. 1 mm above the occlusal plane, in a position harmonious to the canines.

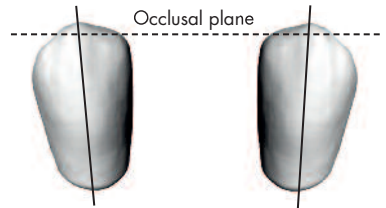

Occlusal view

The centre of the buccal cusp tip lies above the static line.

According to Prof. A. Gerber, the double centric support is very important. As the front teeth stand slightly in front of the alveolar ridge, the upper and lower 1st premolars stabilise the denture. A special feature of the delta shape is to fulfil Prof. Gerber's requirement of double support in the centric position.

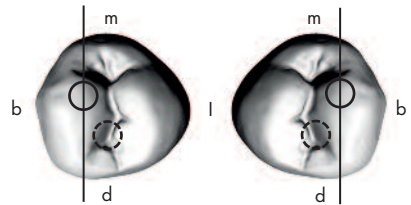

Distal view

From the approximal view, the tooth is slightly inclined lingually and is adapted to the slight lingual inclination of the canine. The buccal cusps of 34 and 44 are at the same height, the cusp tips protrude the occlusal plane by approx. 1 mm.

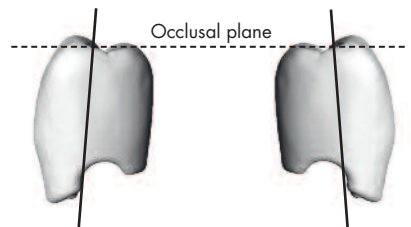

Second lower premolars (teeth 35, 45)

Buccal view

In the buccal view, the lower 2nd premolars, like the lower 1st premolars, stand inclined slightly distal. A small step to the lower 1st premolars must be visible.

The cusp tip and abrasion surfaces of the buccal and lingual cusps are at the same height in this view, as the tooth is set up to inclined slightly lingually. The 2nd premolars are at exactly the height of the occlusal plane / the rubber band.

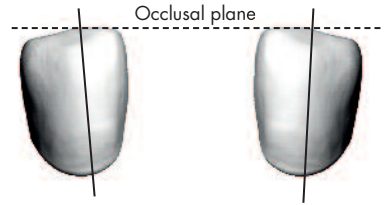

Occlusal view

The central fissure lies above the static line.

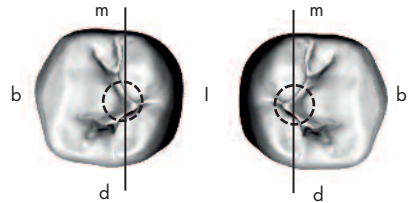

Distal view

In the approximal view, the lower 2nd premolars, like the lower 1st premolars, stand inclined slightly distal. In the delta shape, the buccal cusp tips and abrasion surfaces lie with the disto-lingual cusp tips on the occlusal plane.

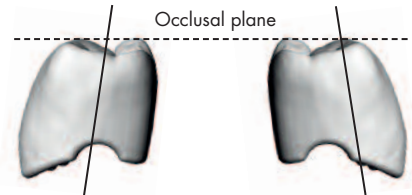

First lower molars (tooth 36, 46)

The position of the first lower molars is described if no 2nd molar (7 tooth) may be set up due to the position of the stop line. This is the case if the distally rising branch of the lower jaw (ramus mandibularis) starts too close to the 1st molar position. This jaw shape is known as saddle jaw.

The position of the lower 1st molars (36, 46) is determined on the basis of the model analysis (marking of the alveolar ridge contour, determination of the masticatory centre and the stop line in the lower jaw).

The occlusal relationship of the lower 1st molars with their antagonists, the upper 1st molars, forms the largest masticatory unit, the masticatory centre. According to the model analysis, the contour of the alveolar ridge in the lower jaw decides whether, after the first molar, a second tooth is to be set up.

Buccal view

1st molar as last molar to be set up (according to the position of the stop line)

The tooth axis is inclined slightly mesially.

The mesio-buccal cusp tips lies at the height of the occlusal plane. The disto-buccal cusp tip protrudes the occlusal plane by approx. 1 mm. Mesial inclination and protrusion of the disto-buccal cusp tip serves to achieve the sagittal compensation curve.

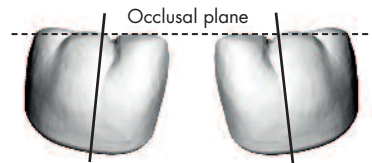

1st molar as last but one molar to be set up (according to the position of the stop line) if a 2nd molar is also to be set up

From the buccal view, the 1st molar lies perpendicular to the occlusal plane.

The cusp tips lie on the height of the occlusal plane.

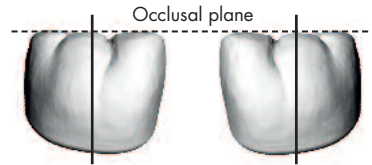

Occlusal view

The central fissure lies with its centric areas along the static line.

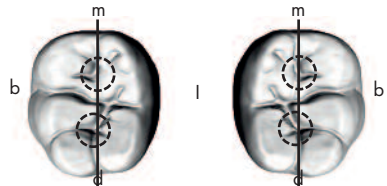

Approximal view mesial

The tips of the mesio-buccal and mesio-lingual cusps lie on the same height and therefore exactly on the height of the occlusal plane.

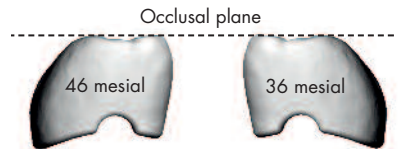

Approximal view distal

The tips of the disto-buccal and disto-lingual cusps lie on the same height and protrude the occlusal plane (rubber band) by approx. 0.5 - 1.0 mm if the 1st molars are the last molars set up.

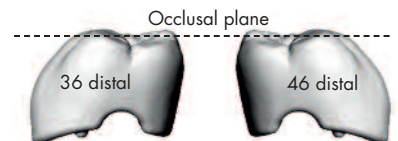

Second lower molars (tooth 37, 47)

The 2nd molars (7 teeth) may only be set up if the position of the stop line allows this. There must be sufficient space available mesial of the stop line for the 2nd molar. No tooth is set up with antagonist contact distal of the stop line such that no anterior sliding, as described by Prof. Gerber, is caused. The position of the 2nd molar corresponds to that of the 1st molar if it is the last tooth.

The lower row of posterior teeth should always extend somewhat more distally than the row of upper posterior teeth, to ensure supporting contact with protrusion in the distal region of the teeth in the lower jaw.

Buccal view

The tooth axis is inclined mesially to achieve a sufficient sagittal compensation curve. The mesio-buccal cusp tip and the disto-lingual cusp tip lie on the same height as the rubber band (occlusal plane).

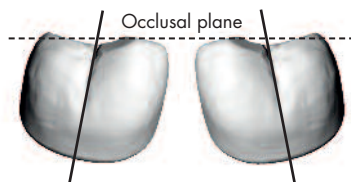

Occlusal view

The central fissure lies with its centric areas along the static line.

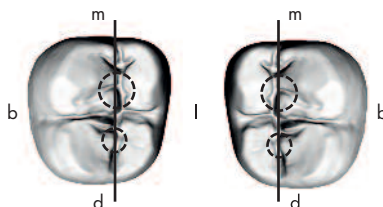

Approximal view mesial

The tips of the mesio-buccal and mesio-lingual cusps lie on the same height as the occlusal plane.

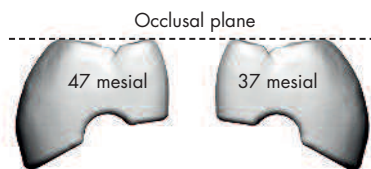

Approximal view distal

The tips of the disto-buccal and disto-lingual cusps are at the same height and protrude the occlusal plane by approx. 1.0 mm.

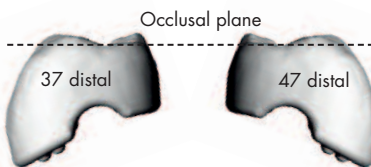

4. SETTING UP THE POSTERIOR UPPER JAW

Upper 1st premolars (14, 24)

According to Prof. Gerber, the posterior teeth occlude on the basis of the mortar-pestle principle. This occlusion concept is enabled by the tooth-to-tooth relationship in balanced, lingualised occlusion. This means that centric contacts only exist between the main antagonists, e.g. 4-4, 5-5, 6-6 and possibly 7-7 teeth, provided the last molar can be set up, depending on the position of the stop line.

Buccal view

Mesially there is approximal contact to the canine, set up without gaps if possible.

The tooth axis is slightly inclined distally (approx. 10°), depending on the lower 1st premolars.

The buccal cusp tips lie almost on the same height as the canine tips; likewise, the cusp tips of the buccal and palatal cusps are on the same height and therefore parallel to the occlusal plane.

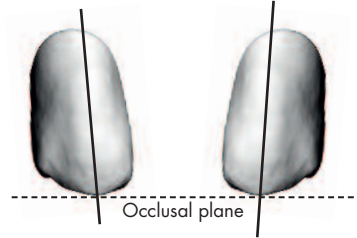

Occlusal view

The centre of the mesial fossa lies above the static line.

According to Prof. A. Gerber, the double centric support is very important. As the front teeth stand slightly in front of the alveolar ridge, the upper and lower 1st premolars stabilise the denture. A special feature of the delta shape is to fulfil Prof. Gerber's requirement of double support in the centric position.

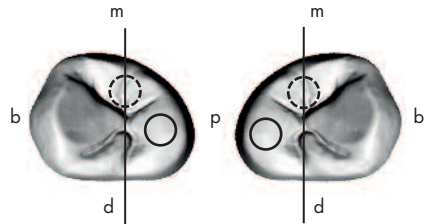

Distal view

The upper palatal cusp has centric contact with the lower 2nd premolar in the distal fossa.

The buccal cusp tip of the lower 2nd premolar has centric contact in the mesial fossa of the upper 2nd premolar.

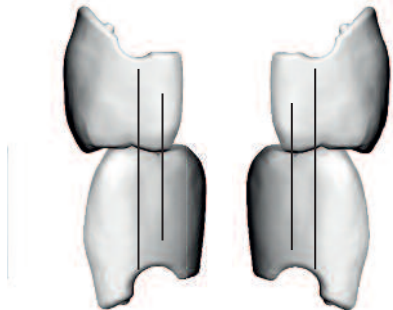

Upper 2nd premolars (teeth 15, 25)

Buccal view

The tooth axis is slightly inclined distally, depending on the lower 2nd premolars. The buccal cusp has no contact with the buccal cusp of the antagonist, the lower 2nd premolar; there is an approx. 0.5 - 1.0 mm distance, known as the freeway space.

The palatal cusp has contact in the fossa of the antagonist, the lower 2nd premolar.

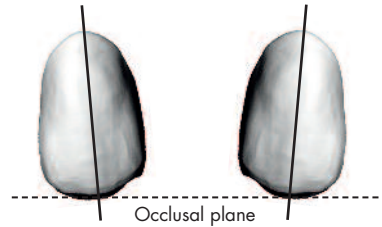

Occlusal view

The centre of the palatal cusp lies on the static line.

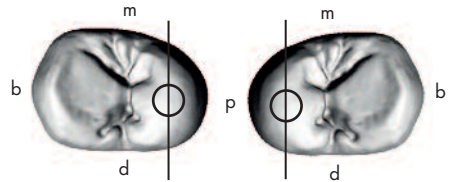

Distal view

The centre of the palatal cusp of the upper 2nd premolars is above the middle of the alveolar ridge in the upper jaw (static line).

The palatal cusps of the upper 2nd premolars have centric contact in the fossa of the lower 2nd premolars.

The buccal cusps have no contact with the antagonists; there is an approx. 0.5 - 1 mm distance, known as the freeway space.

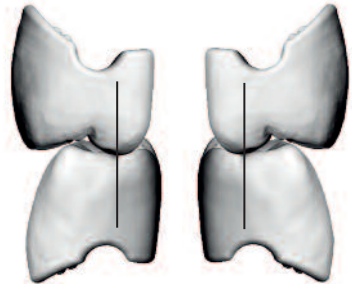

Upper 1st molars (tooth 16, 26)

The alveolar ridge contour and the stop line, determined as part of the model analysis, are essential in deciding whether a 2nd molar can be set up.

Buccal view

The tooth axis is slightly inclined mesially, depending on the position of the lower 2nd premolar (antagonist).

The mesio-palatal cusp has centric contact in the central fossa, and the disto-palatal cusp in the distal fossa of the antagonist, the lower 1st molar.

The buccal cusps of the upper 1st molars have no contact with the buccal cusps of the lower 1st molars; there is a freeway space / interocclusal distance of approx. 0.5 - 1 mm.

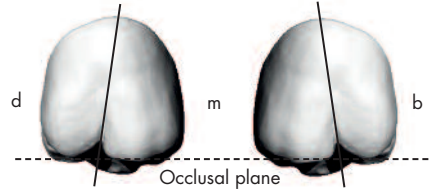

Occlusal view

The midpoints of both palatal cusps are above the static line.

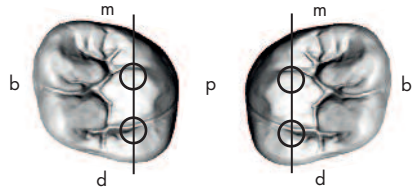

Distal view

As with the upper 2nd premolars, the midpoint of the palatal cusp lies above the static line.

This cusp is the most important supporting cusp in the entire dentition and has contact in the centric fossa of the lower 1st molar. Buccally there is no contact with the antagonist (freeway).

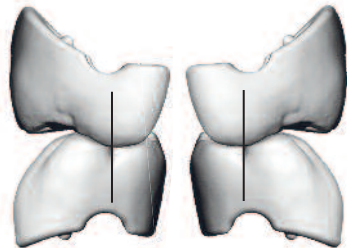

Upper 2nd molars (tooth 17, 27)

Only given an alveolar ridge contour with sufficient rising branch in the distal region is a 2nd molar set up. The upper 2nd molar must not be set up as antagonist of the lower 2nd molar in a saddle shaped alveolar ridge, as it acts as an inclined plane. As soon as there is antagonist contact on occlusion, biting and chewing, the denture tips diagonally; on simultaneous bilateral contact the lower jaw is pushed forwards and downwards (= anterior sliding). If, for static reasons, no 2nd molar is set up in the lower tooth set-up, the 2nd molar is also dispensed with in the upper jaw.

Buccal view

The tooth axis is somewhat inclined mesially, depending on the position of the lower 2nd premolar (antagonist).

The mesio-palatal cusp has centric contact in the central fossa of the lower 2nd molar.

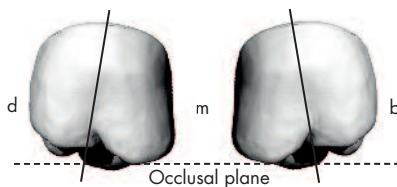

Occlusal view

Like the palatal cusp of the upper 1st molar, the two palatal cusps of the upper 2nd molar also have their cusp centres on the static line.

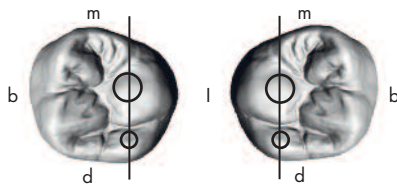

Distal view

The palatal cusps of the upper 1st molars lie above the middle of the static line, as do the palatinal cusps of the upper 1st molars. These are also centric cusps that form centric supporting contacts in the central fossa of the antagonists. The buccal cusps have no contact with the antagonists (freeway space).

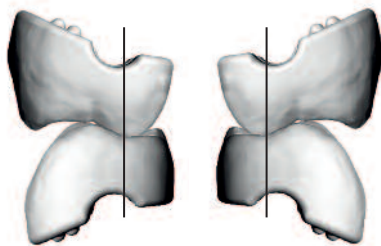

5. SELECTIVE GRINDING IN

Die The simulation of the tooth-guided movements should be performed for mediotrusion and laterotrusion with approx. 2 mm respectively.

Protrusion is simulated up to the contact position of 41 to 11 and 31 to 21 and retrusion up to approx. 0.5 mm.

Colour code for centric and tooth-guided movements:

Centric	RED
Protrusion	BLUE
Mediotrusion	GREEN
Laterotrusion	GREEN
Retrusion	BLACK

The centric, supporting cusps are not ground (upper jaw all palatal cusps and lower jaw buccal cusps of the 1st premolar), but only in the fossa of the antagonists in the lower jaw.

The centric support in lingualised occlusion according to Prof. Gerber is only provided from the upper palatal cusps of the first and 2nd premolars, 1st molar and 2nd molars (if they are set up) and the buccal cusps of the lower 1st premolars. Only the fossae of the antagonists are ground in.

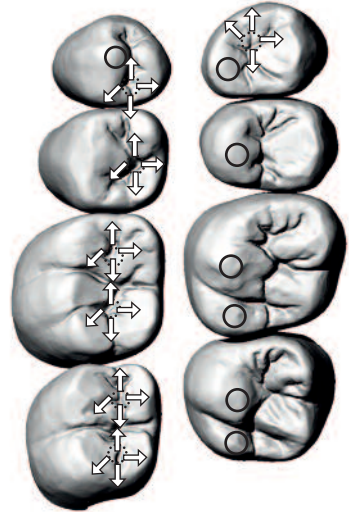

GRINDING IN FOR BALANCED OCCLUSION

CENTRIC

Only grind in the fossae of the antagonists, not the cusps.

In the lower jaw, only the 1st premolar, in the upper jaw the 2nd premolar, 1st and 2nd molars.

LATEROTRUSION

In the lower jaw movement, the lower jaw moves starting at the medial plane on one side, e.g. to the right. This side is then termed the laterotrusion or working side.

The other side of the jaw moves to the median plane, in this case leftwards. As this side of the jaw moves towards the median plane, it is termed the mediotrusion or also the balance side.

Only grind in the fossae of the antagonists and not the cusps.

In the lower jaw, only the 1st premolar, in the upper jaw the 2nd premolar, 1st and 2nd molars.

PROTRUSION

Starting with the lower fossae distally, on the upper 1st premolar mesially.

On the upper jaw front teeth on the incisal edge palatally.

On the lower jaw front teeth on the incisal edge palatally.

The front is ground until the 1st molars have distal contact.

RETRUSION

Starting with the lower jaw fossae mesially, consider the very short path of movement here, approx. 0.2 - 1.0 mm.

OVERJET SET-UP

In the case of the premolars, the tooth axes are inclined distally, a height difference arises between the distal marginal ridges of the 1st premolars, the mesial marginal ridges of the 2nd premolars and to the molars. The height differences have to be identifiable as small steps.

When selectively grinding in the tooth-guided movements, grinding takes place around these steps, such that there is support at every posterior tooth during protrusion.

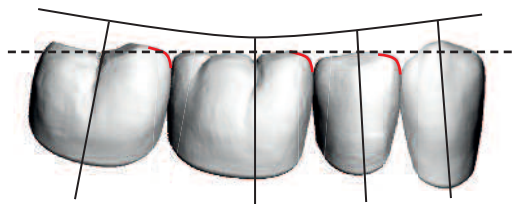

Merz Dental GmbH

Eetzweg 20 24321 Lütjenburg, Germany

Tel + 49 (0) 4381 / 403-0

Fax + 49 (0) 4381 / 403-403

www.merz-dental.de

EN ISO 13485

